

ETA Buffer and Hydraulic Modules



... my heating system



**Systematic heat distribution.
The energy concept from a single source.**

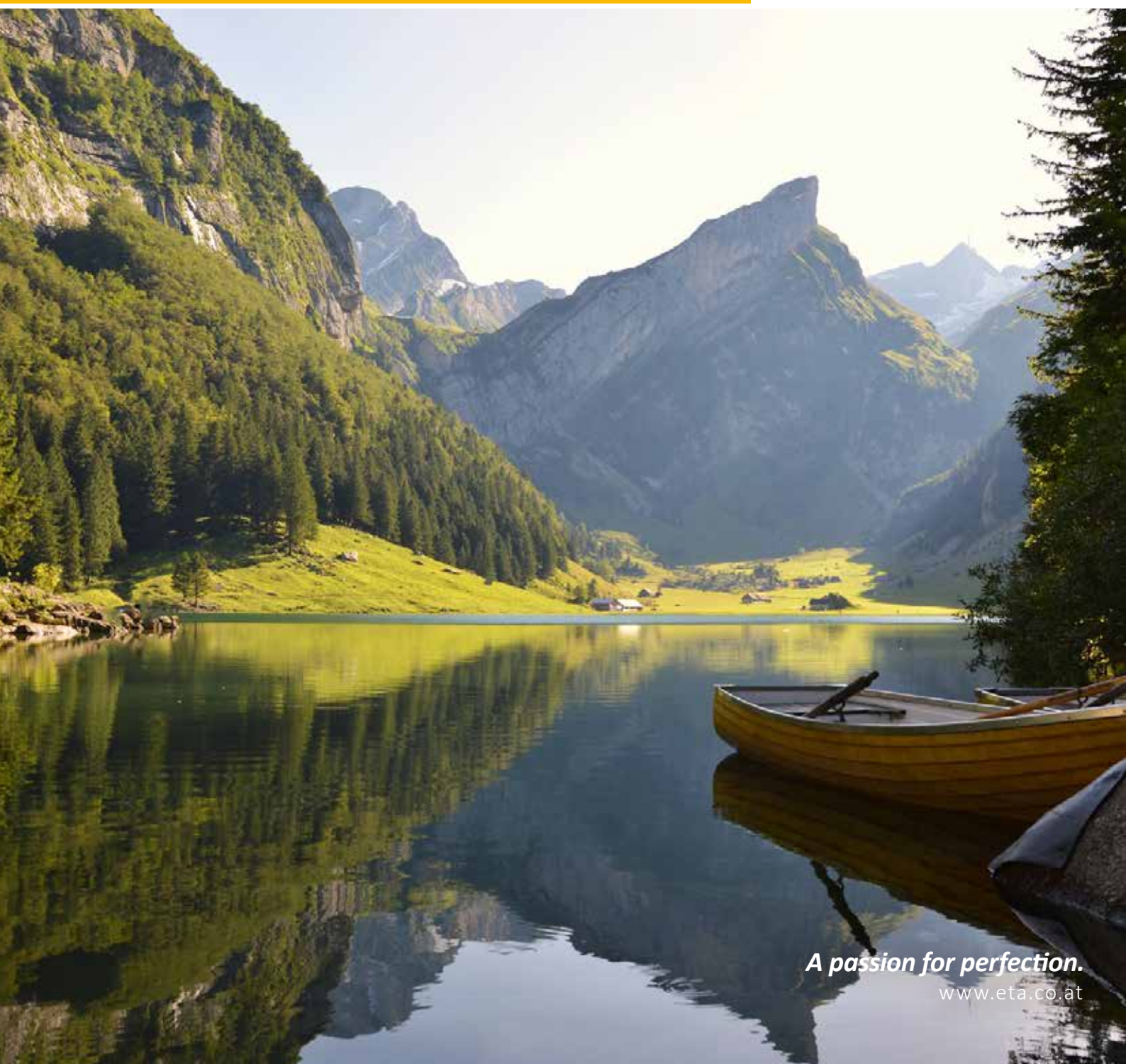
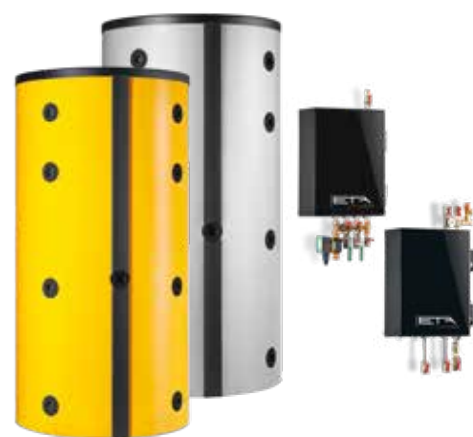

A passion for perfection.
www.eta.co.at

Everything fits together

Whether a small single-family home or an extensive local heating network: a heating system of any size is only as good as the interaction of its individual components. That's why ETA has the right solutions for differing needs in its product range: whether you want to integrate a solar heating system, connect multiple boilers or set up a hygienic hot water supply. Nothing has to be improvised and no extensive planning is necessary. The most diverse of requirements are met by ETA as standard. Just connect the right modules – done. Everything runs via one control system, all components match perfectly. This makes your system safe and saves time during installation.

The buffer:

The heart of the heat distribution system

Heat is stored here, which in turn can be accessed at any time if more energy is needed. The buffer evens out peak and reduced loads and thus ensures a uniform and more efficient operation of the heating system and also a longer lifetime of the boiler. A well-adjusted stratified buffer increases the convenience enormously. For split log boilers, this allows for refueling intervals to be extended for up to several days. A buffer is also a must for a hygienic fresh water supply. ETA offers different sizes – and the particularly economical ECO model.

The hydraulic module:

The right system for all eventualities

No two heating systems are alike. Previously, the different requirements such as the integration of solar heating systems, the connection of multiple buffers or the separation of heating circuits had to be laboriously planned. For implementation there were no ready-made solutions including the control system; commissioning and in particular the cabling was often very time-consuming. That's why ETA has developed modules for different requirements, which can be freely combined with one another and always work as a perfect system.

ETA module family:

- **The fresh water module** always ensures a hygienic supply of drinking water.
- **The stratified charging module** ensures that the energy from a solar heating system is also used optimally.
- **The mixing circuit module** is a ready-made cabled system for two heating circuits. Installation is child's play.
- **The system separation module** separates heating systems, for example an outdoor heating system for the frost protection of the heating system in the house, or an old system from a new one.
- **The heat transfer module and station** are used in local and district heating networks.



Who needs a buffer?

In principle, everybody. A buffer raises the value of any heating system, increases the efficiency and reduces the operating costs.

Buffer in the event of irregular heat requirements: Fire produces a certain minimum amount of energy. The combustion process cannot be throttled back unlimited. If very small amounts of energy are needed, this need can only be handled with buffer. If, for example, the heating requirement is less than the energy that a boiler produces, the buffer stores the excess heat and then slowly releases it back. The boiler starts less frequently, it doesn't waste any energy. If, on the contrary, suddenly large amounts of energy are required, for example if a lot of hot water is needed at once, the boiler cannot react that quickly. But the buffer can.

So a buffer is a must:

- For very small heat requirement during the change of seasons.
- In low energy houses
- If a single room control system is used
- If apartments are to be individually regulated in apartment blocks
- For heating fans that have to heat a room quickly
- In buildings whose structural masses store hardly any heat, for example in wooden houses that are heated with radiators

- If a solar heating system is integrated in the heating system, in order to be able to make full use of the freely available solar energy
- If multiple boilers are connected together to a system
- For split log boilers: the better the buffer works, the less refueling is required
- If a heating was dimensioned larger than required, for example if an extension of the heated area is planned for later
- For high hot water requirements at peak times – for instance in hotels, sports facilities, or apartment blocks
- For systems that have a small hot water preparator in comparison to hot water consumption
- For systems with fresh water module for hygienic supply of hot water



ETA info: To protect the boiler and the whole system, a system with buffer must be filled with softened water. This prevents boiler scale and ensures a long lifetime for the system!

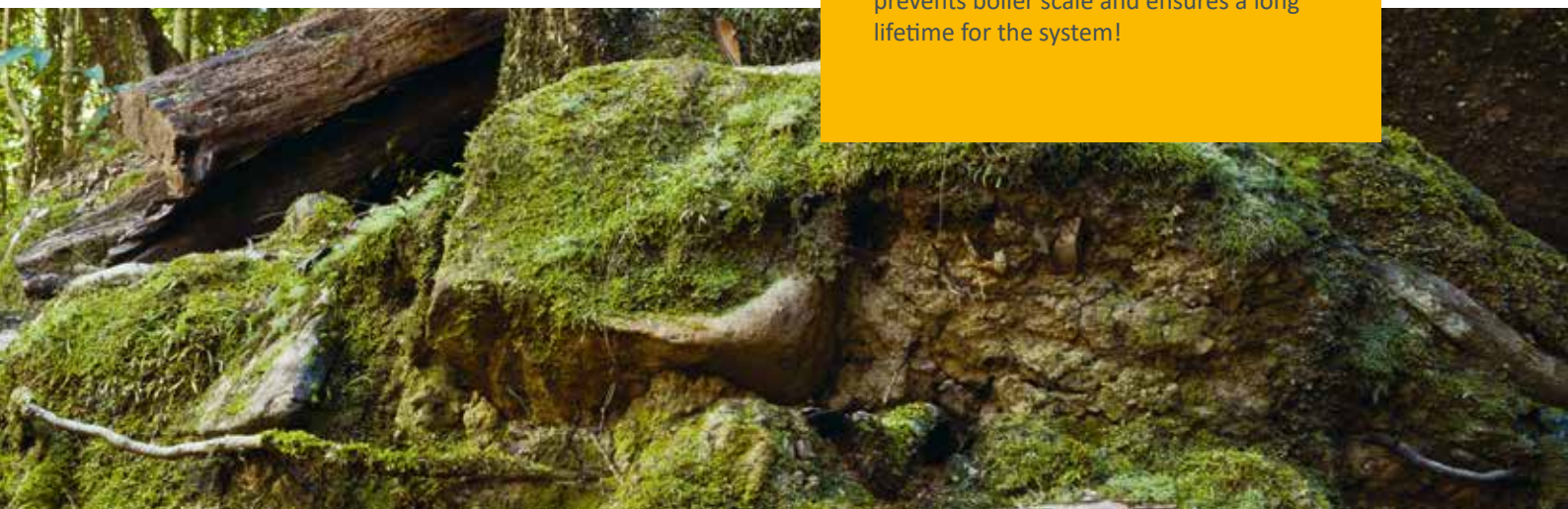



The right temperature, layer by layer



ETA has developed a unique stratified charging concept, at the heart of which is the buffer charging management. It knows precisely when and how much the tank can ideally be charged and when heat will be provided to the consumer again. The entire buffer management can be regulated and controlled via the boiler touchscreen or via the meinETA internet platform.

Heat rises, cold drops:

That's a physical law that also applies for the water in the buffer. If you always introduce water at the same point in the buffer, regardless of which temperature it is, this leads to a large amount of

mixing in the buffer. That in turn would lead to energy losses. Instead, the water from the heating return, for example, or from the solar heating system is then sent precisely to where it belongs in the buffer - the colder water further down, the hotter further up.

The better the temperature stratification works, the better and more conservatively the buffer works energy-wise. That is why it's important to only move the water slowly. The water infeed ends up in the right stratification of the buffer via special ETA separator plates.





ETA tip: The small champion of saving With the ECO model, ETA has developed a buffer that is very cheap and ideal for anyone who is looking for a small system for load balancing. It's ready-made with insulation and an optimum number of connections. The compact tank fits through any door and is quick to set up. Ideally, you will expand it with the ETA fresh water module that ensures a constant supply of hot water and is space-saving as well.

The sensor pipes are arranged in a way that the control system can work optimally. An immersion sleeve does not need to be screwed in separately, it is already integrated. Thus sensors can be shifted if required, also without having to drain the water.

- 

Depending on the desired temperature, the heating water for the hot water supply is always taken from the right point.
- 

At 70 °C to 80 °C the flow is fed from the boiler
- 

The radiators are fed with water between 45 °C and 65 °C
- 

Between 45 °C and 100 °C hot water is fed from the solar heating system if the sun shines strongly
- 

Between 35 °C and 50 °C return from the hot water tank
- 

Between 30 °C and 45 °C water return from the radiators
- 

Between 30 and 45 °C the water is fed from the solar heating system if there is only little sunshine.
- 

Between 30 °C and 35 °C hot water is fed to the underfloor heating
- 

Between 25 °C and 35 °C return to boiler
- 

Between 25 °C and 35 °C return from fresh water module
- 

Between 22 °C and 70 °C the return goes to the solar heating system
- 

Between 22 °C and 27 °C return from the underfloor heating

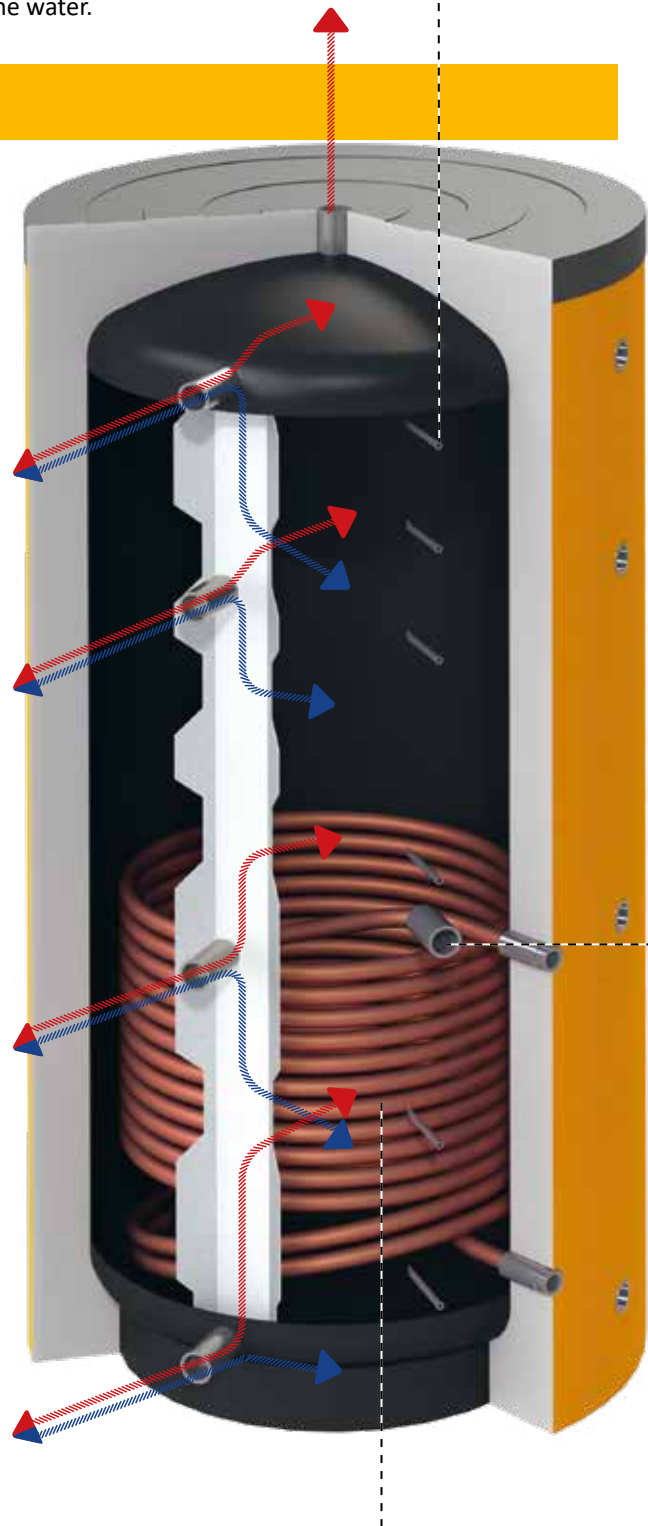

An own solar exchanger is optionally available.

One connection has a screw-in option for an electric heating cartridge, for example.

The larger the better

In principle, the following applies: a buffer can never be too big. More buffer capacity means fewer boiler starts and thus a longer lifetime of the system as well as lower energy costs and increased comfort. Unfortunately, not every boiler room has unlimited space. That's why you can find out here how large your buffer should be in order for your heating system to work efficiently. For split log boilers, this calculation depends on how much fuel fits into the boiler, i.e. from the filling room. For automatically fed boilers, i.e. pellet or wood chip boiler, the

minimum buffer volume is designed for half an hour of full load of the boiler. Furthermore, the required buffer volumes for automatic as well as manually fed boilers depends on the spread. This is the difference between boiler flow and consumer return temperature. With a higher spread only a small amount of water has to be heated and moved. This saves energy – and in this case the buffer can also be dimensioned somewhat smaller.

Calculation example for the log boiler

If the boiler temperature and therefore the upper buffer stratification is at 80 °C, this results in the following minimum requirements for the buffer – depending on the fuel chamber content and the spread:

Return temperature	30 °C	40 °C	50 °C	60 °C
Spread	50 °C	40 °C	30 °C	20 °C
Minimum recommended buffer volume for ETA SH 20–30 with a fuel chamber for 150 l firewood	1,200 l	1,500 l	2,000 l	3,000 l
Minimum recommended buffer volume for ETA SH 40–60 with a fuel chamber for 223 l firewood	1,800 l	2,200 l	3,000 l	4,000 l

Caution:
In Germany, for manually fed boilers legally a minimum buffer volume of 55 Litres per kilowatt boiler output are required.

ETA tip: For high grade firewood like beech, larger buffers are recommended for operation during the change of seasons, for hot water preparation in the summer as well as to keep the refill intervals as long as possible.

A simple rule of thumb applies for this:

Fuel chamber content of the boiler x 10 = minimum required buffer volume.
Fuel chamber content of the boiler x 15 = optimum buffer volume for best energy utilization and ideal comfort.

Calculation examples for wood chip and pellet boilers. If the boiler temperature and therefore the upper buffer stratification is at 70 °C, this results in – depending on the spread for a boiler with 90 kW output the following minimum requirements for the buffer:

Return temperature	30 °C (e.g. underfloor heating)	50 °C (e.g. radiator heating)
Spreizung	40 °C	20 °C
Minimum recommended buffer volume that can handle a half hour of full boiler load	968 l	1,935 l

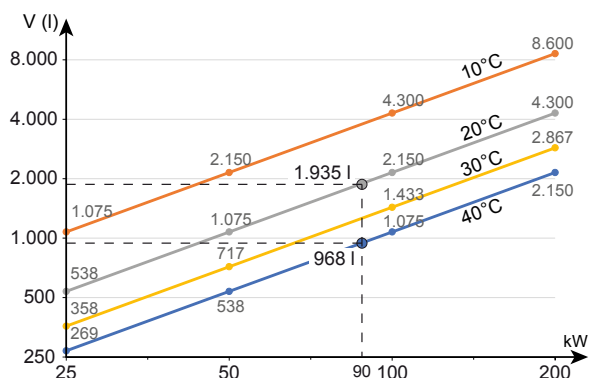

Caution: To meet subsidy requirements, at least 30 litres of buffer volume per kilowatt boiler output are required in Germany for automatically fed boilers!

High buffer capacity despite low ceilings

You would like to use large buffer capacities to maximize the efficiency and comfort of your system, but the room height of your utility room makes that impossible? No problem: If the room height isn't big enough for a large buffer, with ETA you can simply connect multiple small buffers in parallel or in series. It is ideal if they are the same size. But it's

also no problem to connect buffers of different sizes. Even barriers such as a door between the tanks can be overcome.

Caution: When planning a buffer, not only the room height has to be considered but also the size of the doors as the buffer has to first get into the room!



For two tanks of the same size to be easily connected without a lot of effort: the ETA buffer tank connecting set.



For systems in which two or more different size tanks are connected, or when barriers lie between the tanks, ETA have their own planning documents.

Neodul-plus: the cover for the tank

The better a buffer is insulated, the less heat is lost. ETA not only delivers the ideally suited cover for the tank but also insulates the connections!

The insulating materials and their arrangement ensures the best insulating properties. They are provided with wedge-shaped incisions that ensure that the insulation can optimally fit the tank.

Clean and safe. The insulation is surrounded by smooth polystyrene, which is easy to clean. A plastic strip facilitates orderly wiring from the temperature sensors to a cable duct on the boiler room ceiling. This also means that a sensor cannot be pulled out accidentally.

Easy assembly. The assembly can be carried out by one person alone. A special glue makes sure of this, which already ensures optimum adhesion after just

30 seconds. How easy the assembly is can be seen in a video at www.eta.co.at

Advantages in overview:

- Easy assembly by just one person
- Low standby losses (lambda value of 0.032 W/mK)
 - ▶ Class C insulation:
 - Jacket insulation thickness: 100 mm
 - Top insulation finish: 100 mm
 - Bottom insulation finish: 50 mm
 - ▶ Class B insulation:
 - Jacket insulation thickness: 120 mm
 - Top insulation finish: 150 mm
 - Bottom insulation finish: 50 mm
- Optimum fit of insulation
- Optimized insulation for the connections
- Insulating cover for connections that are not needed
- Polystyrene cover for simple cleaning in shiny yellow
- Hook strip with cover for clean installation of sensor cables
- Low weight

A pleasant temperature, one room at a time

Cool in the bedroom, cosy in children's room, 22 °C on weekdays in the office and in the training room only when it's used... Individual control of the temperature in different rooms allows for more comfort at lower operating costs. The ETA individual room or zone control system makes it possible!

Up to 16 different rooms or zones can be defined and individually controlled. This means the ETA individual room or zone control system is equally suited for single-family houses, larger apartments, public buildings or office buildings. The heat distribution, which is adjusted to the exact requirements, saves heating costs and protects resources.



To play, do homework and read, it has to be nice and warm in the **children's room**. Then, before bedtime, it's ok if the room cools down a bit.

The **hallway** remains comfortably cool, so that no one breaks into a sweat while getting dressed.



Everything at a glance! The ETA room sensor displays the room temperature and the outside temperature and enables individual control of each room.

Lots of work or nothing to do? The **home office** is heated more when it's actually used.

If the oven and cooker are on in the **kitchen**, simply reduce the heat supply. So the cooks won't break into a sweat.

Cosy warmth for the main evening film: even the **living room** can be controlled separately.



Room sensor without control elements.
For rooms in which it is sufficient to set the desired temperature on the boilers control panel ETA provides also a room sensor without control elements and display.

Especially on work days, it should be comfortably warm in the **bathroom** early in the morning – and again in the evening.



Each room can be controlled separately in an intuitive manner.

With the tap of a finger

It is very easy to operate and just as intuitive as the entire heating controller via the touch display directly on the boiler, the ETA room sensor with display in the living area or also via the internet platform meinETA from any PC, tablet or smartphone.

Only with buffer

Practical individual room control requires a buffer from which the required amount of heat can be removed as needed. Only then is the heating system flexible enough. In addition, this also reduces the on/off cycles of the boiler to a minimum. This ensures gentle operation and saves energy.

Technical data

- For each controlled zone (one or more rooms) one digital ETA room sensor (with or without control elements) is needed.
- Only compatible with ETAtouch controllers made after May 2013 (GM-C2 circuit board)
- Maximum 2 valve controllers per ETAtouch controller
- Up to 8 outputs are possible per valve controller
- Each output on the valve controller may be loaded with a maximum of 20 W.
- However, the total output of all actuators connected to a valve controller may not exceed 100 W.
- Thermoelectric actuators with an operating voltage of 230 V required
- The valve controllers are suitable for top-hat rail assembly

Always hygienic, always fresh

The buffer not only supports the heating system so that you can enjoy more comfort at lower operating costs, it also ensures that you always have hot water on tap. Ideally in combination with the fresh water module. Legionella bacteria do not stand a chance this way, as hot water is always heated fresh and hygienically.

Shower more often, heat less often

The fresh water module ensures that the buffer is used more efficiently. This is due to the low return temperatures of under 30 °C. A 1,000 litre buffer content at 80 °C in combination with a hot water tank are enough for 18 to 24 showers. In combination with a fresh water module, at 80 °C you can enjoy about 30 hot showers for the same amount of buffer water. Not only does that save energy, it also protects the boiler and means more comfort – especially for log boilers! Whilst an automatic boiler doesn't have to start so often, for log boilers - especially in summer - it means much less chopping wood, going to the basement and lighting the boiler!

Hot water for all

The ETA fresh water module is more generously dimensioned than other fresh water modules on the market. It can supply three showers or taps simultaneously, exactly like a hot water tank, so nobody in the house has to be without hot water!



ETA info

Our fresh water module functions with a special plate heat exchanger (MicroPlate®) on or next to the buffer. The heat from the buffer is used to prepare the hot water the moment you need it. Thus fresh, hygienically perfect water comes out of your pipes at all times.

No fear of limescale

If water is heated above 60 °C, limescale formation dramatically increases. Especially for standing water in hot water tanks, the accumulated lime can lead to inconvenient damage. That doesn't happen with an ETA fresh water module! Here, limescale is low for two reasons: On the one hand the hot water in the heat exchanger is kept below the limescale temperature by return admixing, on the other any limescale that forms is immediately flushed away by the high flow speed in the heat exchanger. Although water softening for the fresh water module is only necessary in exceptional cases, it is often advisable for many household appliances such as coffee machines, washing machines or dishwashers.





ETA hot water circulation set: Quick, also for long distances

If all bathrooms, the kitchen with its sinks, and other taps are close to the hot water producer, it is of course ideal: simply turn the tap and hot water can be used straightaway. If though a bathroom is 15 or 20 meters from the heat producer, it means waiting for the hot water... Or use a hot water circulation set.

Hot water, as you need it: Conventional hot water circulation systems send some hot water through the pipes from time to time, mostly every hour. With ETA it's different. Here, hot water only circulates when required – and naturally that saves energy!

The intelligent autoloop function: It creates an individual profile of the hot water usage for your household. In the beginning the data of the previous day is used, then later the last 7 or 14 days, so that hot water is always available when you need it. So no more waiting for hot water to come along. This increases comfort, saves water and energy.

If you wish, the circulation can also start by opening the tap

Of course the circulation pump also starts manually on request. Even with longer pipes, after just a short time hot water flows out of the tap. Additionally, an individually adjustable time regulation is also possible. If, for instance, you shower daily at 7 o'clock, simply set a circulation for 6:50. Then the hot water is already waiting for you!*



ETA info

Easily installed. The ETA fresh water module is already set up for a circulation set. A defined connection and a pre-assembled set enable a quick and smooth installation.

**These functions can only be optionally activated with a connection to the ETA Touch Panel!*

Hygienic and fresh from the buffer:

Fresh water module ETA FWM 33 and 44

Easy to install and space-saving too. The ETA fresh water modules do not need much space and can either be directly mounted on the buffer or on the wall. The installation effort is minimal as all components are already assembled and pre-wired. Just wire the power connection and the bus line to the ETA touch control system and connect the buffer sensor to the module circuit board terminals. Even the pipework effort is minimal.

If you don't have an ETA control system but would still like to use our fresh water module, that's also no problem. It works without touchscreen too. Simply set the desired temperature on a rotary knob and use the circulation via the ETA Autoloop function.

Works economically. The high-efficiency pumps are then only activated when you actually need hot water. The speed is kept as low as possible depending on the desired temperature. As no hot water is produced for reserves, there are hardly any heat losses with the ETA fresh water module.

You have aggressive water and are afraid of corrosion of the heat exchanger?

We have a special INOX version of the stainless steel exchanger (also for retrofitting) for you! You can roughly determine the conductivity of your water through the hardness of the water, which is the main factor for the corrosion of a conventional heat exchanger. For those the critical conductivity starts from 500 μ S

Rule of thumb: Hardness ($^{\circ}$ dH) x 35 = approx. Conductivity (μ S)

- up to 15 $^{\circ}$ dH standard heat exchanger sufficient
 - 15 - 20 $^{\circ}$ dH Copper corrosion may occur
 - over 20 $^{\circ}$ dH INOX heat exchanger recommended
- Although conventional water softening systems reduce water hardness, they have no influence on the conductivity of your water. Use the experience of your heating engineer on site!



Technical data

Corresponds to DIN DVGW or ÖNORM B5014-3

FWM 33:

tap output 33 l/min. with 45 $^{\circ}$ C at 60 $^{\circ}$ C buffer temperature

Pressure loss on drinking water side:

33l/min = 580mbar (5,8mWc); 15l/min = 150 mbar (1,5mWc)

FWM 44:

tap output 44 l/min. with 45 $^{\circ}$ C at 60 $^{\circ}$ C buffer temperature

Pressure loss on drinking water side:

44/min = 560mbar (5,6mWc); 20l/min = 160 mbar (1,6mWc)

Plastic cover H=600 mm, W=400 mm, D=190 mm

Cascadable for greater tap outputs

Scope of delivery

The module is delivered as a whole unit already pre-assembled on a mounting plate and contains:

MicroPlate® plate heat exchanger:

Heating side:

- Speed-controlled high-efficiency pump in buffer circuit with check valve
- Speed-controlled high-efficiency pump for return admixing (limescale protection) with check valve
- Bleed valve (manual)
- Connecting ball valves 3/4" (FWM 44: 1") internal thread

Water side:

- Flow meter to determine the current tap quantity
- Check valve

- Defined connection for circulation set

- Flush ball valves DN 15 (1/2") and connecting ball valves 3/4" (FWM 44: 1") internal thread according to DIN DVGW or ÖNORM B5014-3

Control system with safety plug:

The components inside the module are already pre-wired.

Control system contains 2 freely available sensors inputs (for poss. connection of the buffer sensors) and an output for the circulation set.

Loosely enclosed:

- CAN-Bus line L=10 m for connection with ETA boiler control system

The system that thinks for itself:

ETA circulation set

The further away the water tapping points are from the hot water producer, the more important a good circulation set is. While conventional systems send some hot water through the pipes from time to time, the ETA circulation set is only active when there's a demand. That saves energy.

- Through manual time entry: For example, anyone who showers at the same time every day can program a fixed circulation for a few minutes earlier (only possible with touchpanel).

This is how the circulation is activated:

- Through the innovative autoloop system – see graphic
- Through briefly opening the tap, the circulation pump starts immediately so that the line is flushed. Hot water flows out of the tap after just a short time, even with longer pipes (only possible with touchpanel).



Technical data

Energy-saving pump
10 bar safety valve, protects the lines from too much water pressure
Circulation line connector DN 20 (3/4") external thread. All components relevant to operation, such as e. g. check valve, are already integrated.

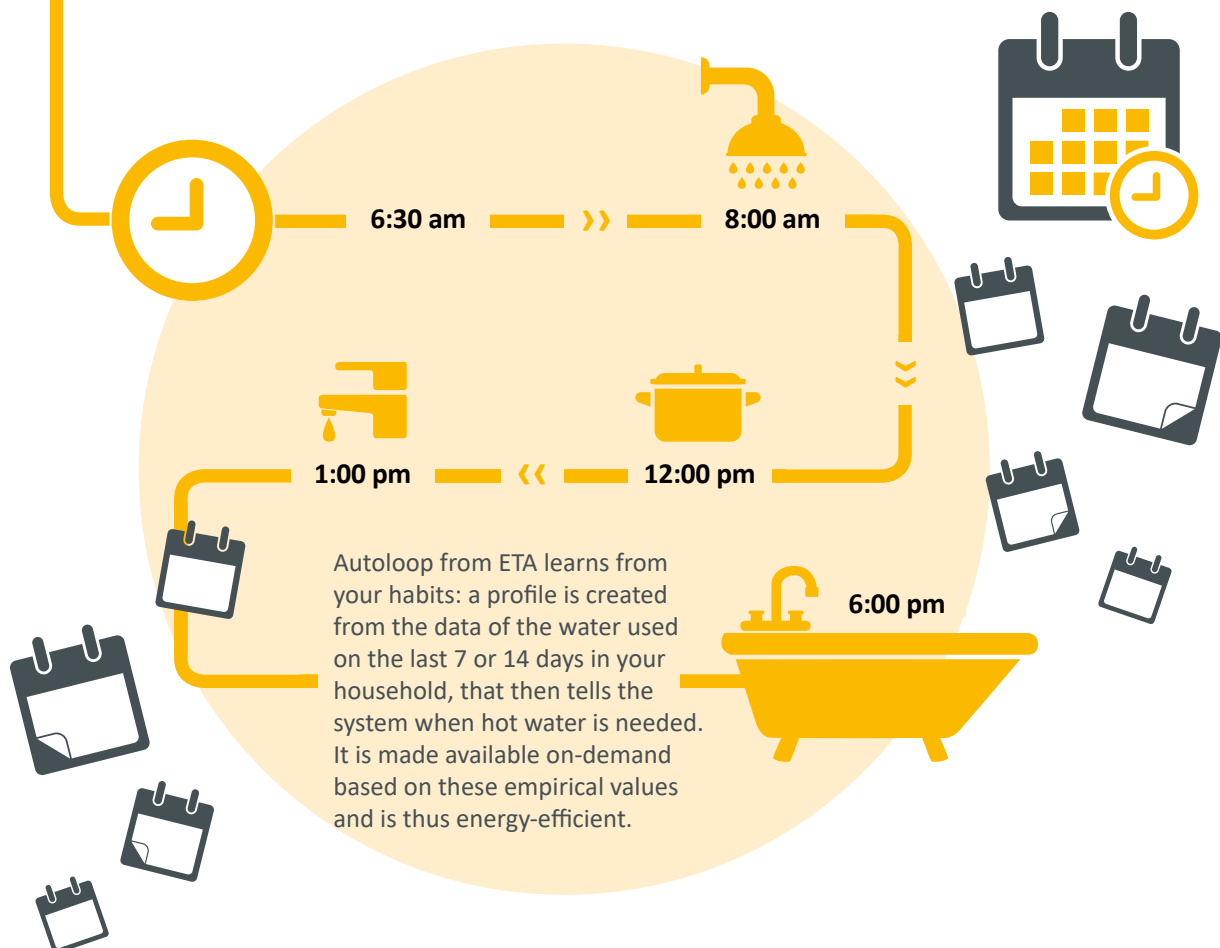

You cannot manage what you cannot measure:

Heat transfer module ETA UGM

The transfer module from ETA is the professional solution for private and commercial heating networks. It is not only suitable for new builds, but also especially good for quick and economical renovations of buildings that don't have their own heating boiler.

The first heating circuit and the hot water charger are integrated into the module and work with just one highly-efficient heating pump. In addition, the ETA module concept and the ETA touch control system also allow any other solution, so that individual systems can be designed. Whether you want to use your old oil boiler or plan a low energy house – everything is possible!

Quick installation: The most important components for local or district heat operators are already pre-installed and pre-wired. This also guarantees a smooth operation from the start. Of course space is already provided for a heat flow meter for energy billing. It can also be supplied right away by ETA on request, just like a piping set for more than one heating circuit.

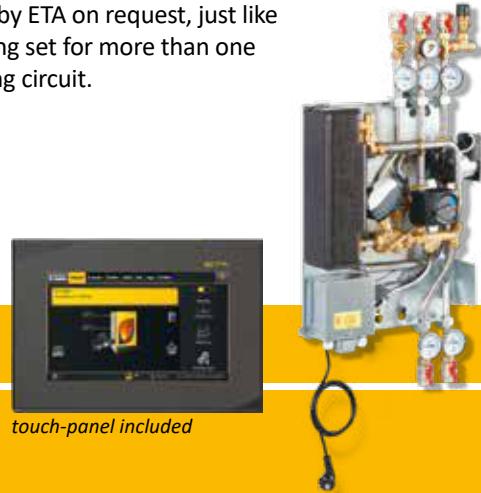

touch-panel included

Technical data

Connecting ball valves DN 20 (3/4") internal thread
Plastic cover H=600 mm, W=400 mm, D=190 mm

Primary side			Secondary side				
Flow/ Return °C	V [m³/h]	Pressure loss	Heating system	Flow/ Return °C	V [m³/h]	Residual head [mWs]	Qmax [kW]
75/43	0,67	1,5	Radiators with or without buffer tank	65/40	0,86	4,8	25
75/33	0,8	1,8	Underfloor heating with mixing valve and buffer tank	65/28	0,9	4,6	38
75/33	0,3	0,9	Underfloor heating controlled directly by the heat exchanger	35/28	1,6	1,7	13

Scope of delivery

The module is delivered as a whole unit already pre-assembled on a mounting plate and contains:

MicroPlate® plate heat exchanger:

Primary side:

- District heating flow valve (kvs=2.5) with differential pressure compensation
- Actuator with constant controlling and active status indication for a precise temperature regulation
- Adapter for heat meter and its flow connection (ultrasound heat meter available as an accessory)
- Stainless steel piping with flat sealing pipe connection
- Strainer

Secondary side:

- High-efficiency pump, adjustable for differential or constant pressure operation and bleed function with check valve as gravity brake
- Changeover valve to load the hot water tank, water quantity adjustable via balancing valve
- Safety valve 3 bar and connection for a membrane expansion tank
- Defined connections for further suction consumers (pipe set or connection set available as accessories)
- Fast reacting clip-on temperature sensor with

stainless steel bracket for flow temperature detection

- Stainless steel piping with flat sealing pipe connections

Control system with safety plug:

Control system already integrated for the integrated mixing circuit and the hot water tank loading or for the buffer charging.

For additional mixing circuits, either the mixing circuit module or a heating control for 2 further mixing circuits is required.

The components inside the module are already pre-wired.

A touchscreen control panel with Ethernet interface is included in the scope of delivery.

Control system contains 5 freely available sensor inputs and an MBUS circuit board for visualization of heat meters with suitable interface.

Loosely enclosed:

- 1 outside- temperature sensor
- 1 immersion sensor

For larger power ranges:

Heat transfer station ETA UGS

The ETA transfer stations are available in 5 output sizes. These compact heat transfer stations are used for direct connection to district and local heating plants for indirect operation.

All components most important for a district heating operator are already pre-installed and pre-wired. The welded construction also simplifies connection to a district heating network. Connection to a household system can also be done easily and individually. The ETA control

is already integrated, and can be optionally expanded as required. The ready-to-connect and future-oriented design enables smooth operation right from the start, and also the option of energy billing using an integrable heat meter.



touch-panel optional

Technical Data

Primary side				Secondary side			
Operation Type		Flow	Return	Heating system		Flow	Return
I	District heating	90°C	42°C	Radiators with or without buffer tank		65°C	40°C
II	Supply by ETA boiler	75°C	43°C	Radiators with or without buffer tank		65°C	40°C
III	Supply by ETA boiler	75°C	36°C	Underfloor heating with mixing valve and/or buffer tank		65°C	28°C
IV	Supply by ETA boiler	75°C	33°C	Underfloor heating controlled directly by the heat exchanger*		35°C	28°C

*If the temperature of the underfloor heating system is controlled directly by the heat exchanger, the limitation of the power output is mainly caused by the decrease in pressure due to the heat transfer station (max. 2 mWs).

Typ	Amount of plates	max. power output [kW]				Primary valve	Primary				Secondary		
	heat exchanger	I	II	III	IV		KVS [m³/h]	Vmax [m³/h]	PN	DN	Vmax [m³/h]	PN	DN
15	16	22	9	18	8	1,6	0,40	16	G1"	0,90	6	Rp 1"	
30	26	35	17	30	12	1,6	0,63	16	G1"	1,41	6	Rp 1"	
40	36	54	25	45	18	2,5	0,98	16	G1"	2,14	6	Rp 1"	
60	50	83	36	65	25	4	1,57	16	G1"	2,96	6	Rp 1 1/4"	
75	60	101	43	95	30	6,3	2,46	16	G1"	3,54	6	Rp 1 1/4"	

Weight: max. 55 kg

Housing dimensions: H = 680 mm W = 650 mm D = 482 mm

Ball valves with integrated bimetallic thermometer

Scope of delivery

The module is delivered as a whole unit already pre-assembled on a mounting plate and contains:

MicroPlate® plate heat exchanger:

Primary side:

- District heating flow valve with differential pressure compensation
- Actuator 230V 3-point
- Immersion sensor for return temperature limitation in the medium
- Adapter for heat meter (ultrasound heat meter optional)
- Sensor connections for heat meter
- Strainer
- High pressure discharge, G3/4" hose connection
- High pressure bleeding G1/4"

Secondary side:

- 3 bar safety valve
- Connection for expansion tank Rp 3/4"
- Immersion sensor for flow temperature detection
- Strainer
- Discharge, G3/4" hose connection

Control system with safety plug:

The T2-W control is already integrated, allowing control of one mixer circuit, four additional pumps and the integrated district heating valve (230 V, 3 point).

The components inside the module are already pre-wired.

The control system contains 5 freely available sensor inputs.

Loosely enclosed:

- 1 outside- temperature sensor
- 1 immersion sensor

Interaction of the products

ETA not only offers the most diverse of products, but also links them logically. Everything runs smoothly and safely. The components in the heating system that are needed always get automatic priority.

The whole system is controlled by ETA so that the interaction works perfectly. It is conveniently controlled via a touchscreen on the boiler or via the internet, mobile or PC.

The integration of existing components or systems in the ETA system is no problem. There are hardly any requirements that the system cannot handle. As the standardized control system is very extensive, very complex systems can also be implemented without a lot of effort. The ETA module family takes over the most diverse of tasks – and is delivered ready to plug in. Each module is connected to the central hub with just one data cable – perfect plug & play for the entire central heating system!

An interface for superordinate instrumentation and control systems and for the QM wood heating stations, a quality management system that is important not only for public systems and subsidies, is already integrated into the system.

All data from the boiler and buffer can be regularly downloaded using a USB stick. It is very easy to evaluate the data, for example also via common systems like Excel spreadsheets. Superordinate control systems can be fed information via ModBus TCP too.



You can control the boiler via smartphone, PC or tablet as well as directly on the touchscreen.

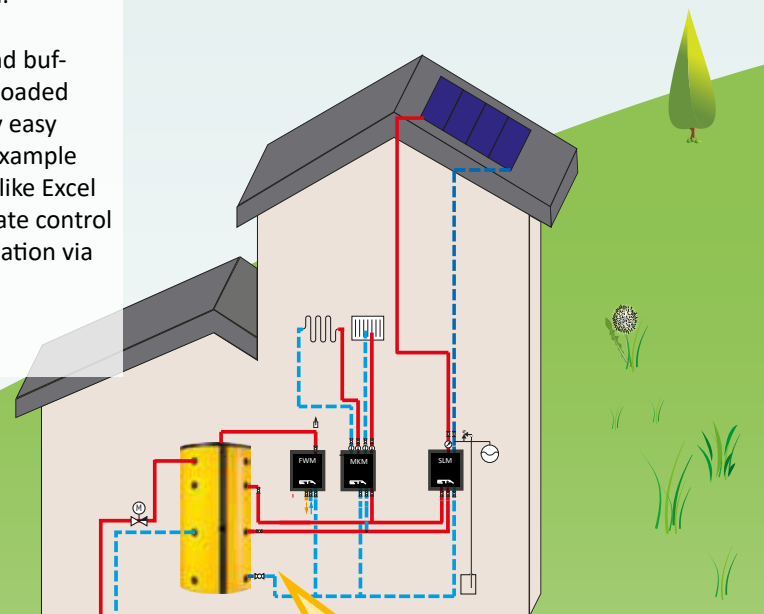

ETA planning service or support.

You don't have to reinvent the wheel, just know how it turns. The **ETA control system** offers a lot of possibilities to integrate existing systems. We support our customers with design advice and a multitude of suggested hydraulic systems.

Here, the **ETA stratified buffer, the fresh water module, mixing circuit module and the stratified charging module** work together perfectly.

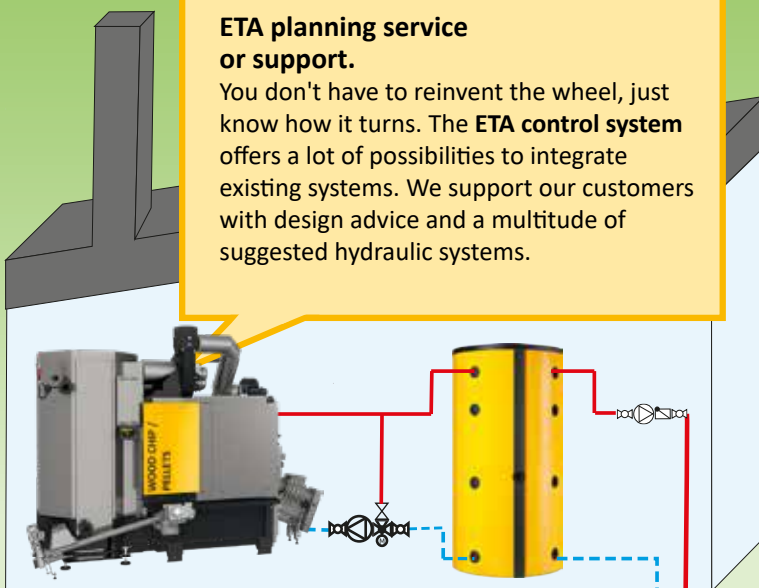

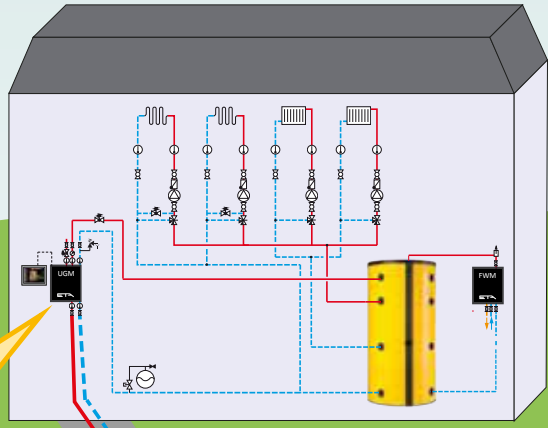
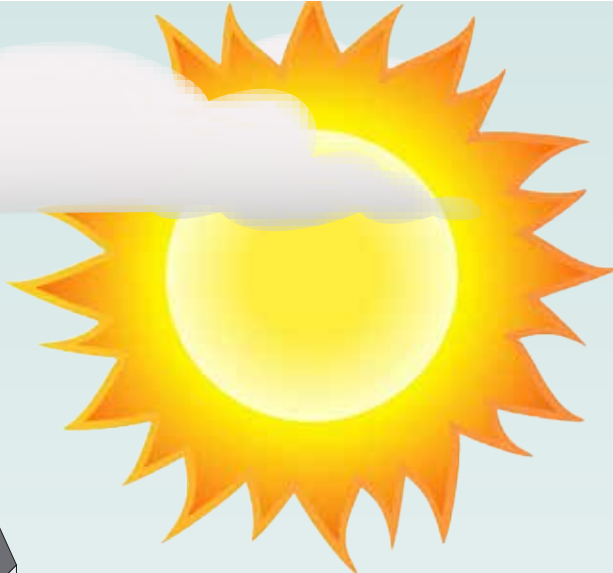

The **ETA transfer module** is the professional solution for private and commercial heating networks. It is not only suitable for new builds but also especially good for the quick and economical renovation of buildings that don't have their own heating boiler.

The **system separation module** ensures safety if heating systems have to be separated: for example stable heating, frost protection facilities or old systems with oxygen leakage.

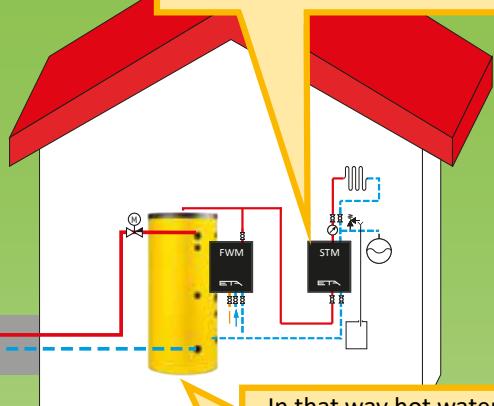
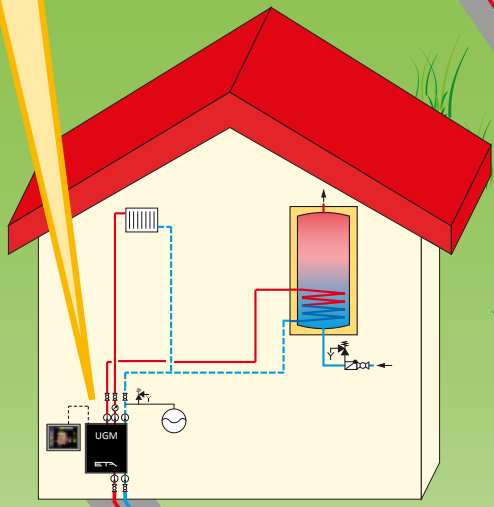

In that way hot water is economically, hygienically and quickly prepared using the **ETA ECO tank** and the **ETA fresh water module**.

Grab the sun from the sky!

A solar heating system is the perfect addition to any biomass boiler, as it delivers energy for the hot water supply as well as for heating even during the change of seasons and in summer, and thus minimizes the boiler starts. Here, the following applies: The better the buffer stratification works, the more free energy you can get from the sky.

ETA offers two solutions for the integration of a solar heating system: An economical integration into the stratified buffer via a solar coil or integration via the ETA stratified charging module that is also very efficient for small and very large systems.

The solar coil is a heat exchanger built into the buffer. If the sun has heated the water in the collector, it is transported to solar coil by a pump and there it passes on its heat to the buffer. To ensure that the system runs efficiently, a collector size of at least 1 m² should be available per 100 litres water in the buffer.

The stratified charging module can also be used for smaller solar heating systems, even with large buffer tank volumes, or very big solar systems and always in cases where the solar coil is not efficient enough. The stratified charging module works with two variable-speed high-efficiency pumps and a plate heat exchanger. Depending on the water

temperature, it automatically switches back and forth between the upper and the lower buffer halves. If the temperature level of the water from the solar heating system is high, it is fed into the hot layer of the buffer on top. If the temperature level from the solar heating system is lower, it can also be used in that it's simply stored further down – in the colder regions of the buffer. These low temperatures can be used very efficiently, especially in conjunction with an underfloor or wall heating system!



Optimally harnessing the power of the sun:

ETA SLM stratified charging module

For larger buffers with more than 100 litres per collector surface square meters or with very small solar heating systems, a stratified charging module ensures efficiency in the integration of thermal solar heating systems. For example in the morning when the sun is weak, the module supplies the lower half of the buffer. Once the sun is sufficiently strong to heat the upper, warmer buffer layer, the system switches to the upper half.



Technical data

1,000 l/h on solar side with 4 mWc external pressure loss for collectors up to 20 m² in high flow for low collector operating temperature with maximum solar yield up to 40 m² in low flow for high collector operating temperature with maximum tank utilization
 Connecting ball valves DN 20 (3/4") internal thread
 Plastic cover H = 600 mm, W = 400 mm, D = 190 mm

Scope of delivery

The module is delivered as a whole unit already pre-assembled on a mounting plate and contains:

MicroPlate® plate heat exchanger:

Solar side:

- Speed-controlled high-efficiency pump, with check valve as gravity brake
- Solar safety valve 6 bar and connection for a membrane expansion tank
- Flow indication
- Flush connections DN 15 (1/2") external thread
- Pressure gauge

Flow meter for heat quantity measurement (NOT CALIBRATED)

Heating side:

- Speed-controlled high-efficiency pump

- Changeover valve for flow stratification in 2 buffer zones
- Safety valve 3 bar
- Bleed valve (manual)

Control system with safety plug:

The components inside the module are already pre-wired.

Loosely enclosed:

- Collector sensor
- 2 immersion sensors (for zone 1 and 2)
- CAN-Bus line L=10 m for connection with ETA boiler control system
- Values for composite label according to ErP guidelines:

Solar pump:

Average power consumption at 50% = 23 W
 Standby consumption integrated controller = 4.3 W

Safely separated systems:

System separation module ETA STM

Whenever heating systems need to be separated from one another, the ETA system separation module is the right choice. Therefore if, for example, one heating circuit is to keep the living area warm and the other serves as frost protection in mews and workshops for instance, or keep outdoor areas free of ice and snow. Also old systems, i.e. ageing underfloor heating systems that take oxygen into the system, or stable heating systems that add ammonia to the heating water, must safely be separated from the rest of the heating system, so that no damage occurs. The technology works in the same way as for solar heating system: the transmission media, i.e. the heating water or anti-

freeze mixture, is carefully separated via a plate heat exchanger.

More efficient than conventional systems

The ETA system separation module works with a variable speed, high-efficiency pump. The respective pump speed determines the required water quantity. In contrast with conventional systems controlled by valves, here only the required amount of water is removed from the buffer. The ETA system is not only economical in its procurement but also protects the wallet day by day in regular operation!

Technical data

Free residual pump head on primary side:

Underfloor heating 13 kW; 75/33 °C; 0.3 m³/h = 7.0 mWc

Radiator heating 40 kW; 75/50 °C; 1.4 m³/h = 3.0 mWc

Free residual pump head on secondary side:

Underfloor heating 13 kW; 35/28 °C; 1.6 m³/h = 2.2 mWc

Radiator heating 40 kW; 65/45 °C; 1.7 m³/h = 1.5 mWc

Connecting ball valves DN 20 (3/4") internal thread

Plastic cover H=600 mm, W=400 mm, D=190 mm



Scope of delivery

The module is delivered as a whole unit already pre-assembled on a mounting plate and contains:

MicroPlate® plate heat exchanger:

Primary side:

- Speed-controlled high-efficiency pump, with check valve as gravity brake
- Stainless steel piping with flat-sealing pipe connections
- Fast reacting clip-on temperature sensor with stainless steel bracket for flow temperature detection

Secondary side:

- High-efficiency pump, adjustable for differential or constant pressure operation and bleed function
- Safety valve 3 bar and connection for a membrane expansion tank

- Stainless steel piping with flat sealing pipe connections
- Fast reacting clip-on temperature sensor with stainless steel bracket for flow temperature detection

Control system with safety plug:

The components inside the module are already pre-wired.

The control system contains 4 freely available sensor inputs and is prepared for an MBUS circuit board for visualization of heat meters with suitable interface.

Loosely enclosed:

- CAN-Bus line L=10 m for connection with ETA boiler control system

Quickly and easily installed:

Mixing circuit module ETA MKM

This is how quickly a whole system can be installed: with just a plug and a data line you've got your heat distribution under control. The ETA mixing circuit module is suitable for all types of heat distribution, i.e., underfloor and/or radiator heating just as much as heating fans.

The ETA mixing circuit module for 2 heating circuits saves a lot of time and money during installation, as no sensor lines, pumps and mixer cables have to be installed. All components are connected to the control system that has already been integrated – and also work correctly, as the system was already precisely tested during production by ETA.

High-quality technology: Two separately laid return connections ensure that, depending on the temperature level, the individual heating circuits are supplied precisely at the right point in the buffer. The

two energy-saving high-efficiency pumps correspond to the European guidelines and the requirements of the funding agencies.

Well packed: The module has solid stainless steel pipework with easy to maintain, flat-sealing pipe connections and high-quality control system and measurement technology. From the outside, it looks like a design element with the shiny black, high-quality plastic cover.

Well regulated: With just one connecting line to the ETA touch control system, you can take advantage of the comfort of a perfectly visualized user interface with remote internet control. You can control your whole heating system with your tablet, mobile or PC from anywhere.

Technical data

Free residual pump head per pump (suction side + pressure side)

Underfloor heating 15 kW; 35/28 °C; 1.9 m³/h = 2.2 mWc

Radiator heating 45 kW; 65/45 °C; 2.0 m³/h = 1.7 mWc

Connecting ball valves DN 20 (3/4") internal thread

Plastic cover H=600 mm, W=400 mm, D=190 mm



Scope of delivery

The module is delivered as a whole unit already pre-assembled on a mounting plate and contains:

2 mixing circuits with:

- High-efficiency pump, adjustable for differential or constant pressure operation and bleed function
- Heating mixer (kv=6) with very low leakage losses and easily visible position indicator
- Actuator with constant controlling and active status indication for precise temperature regulation
- Fast reacting clip-on temperature sensor with stainless steel bracket
- Thermometer for indication of flow and return temperature

Control system with safety plug:

The components inside the module are already pre-wired.

The control system contains 4 freely available sensor inputs and is prepared for an MBUS circuit board for visualization of heat meters with suitable interface.

Loosely enclosed:

- CAN-Bus line L=10 m for connection with ETA boiler control system

NOTES

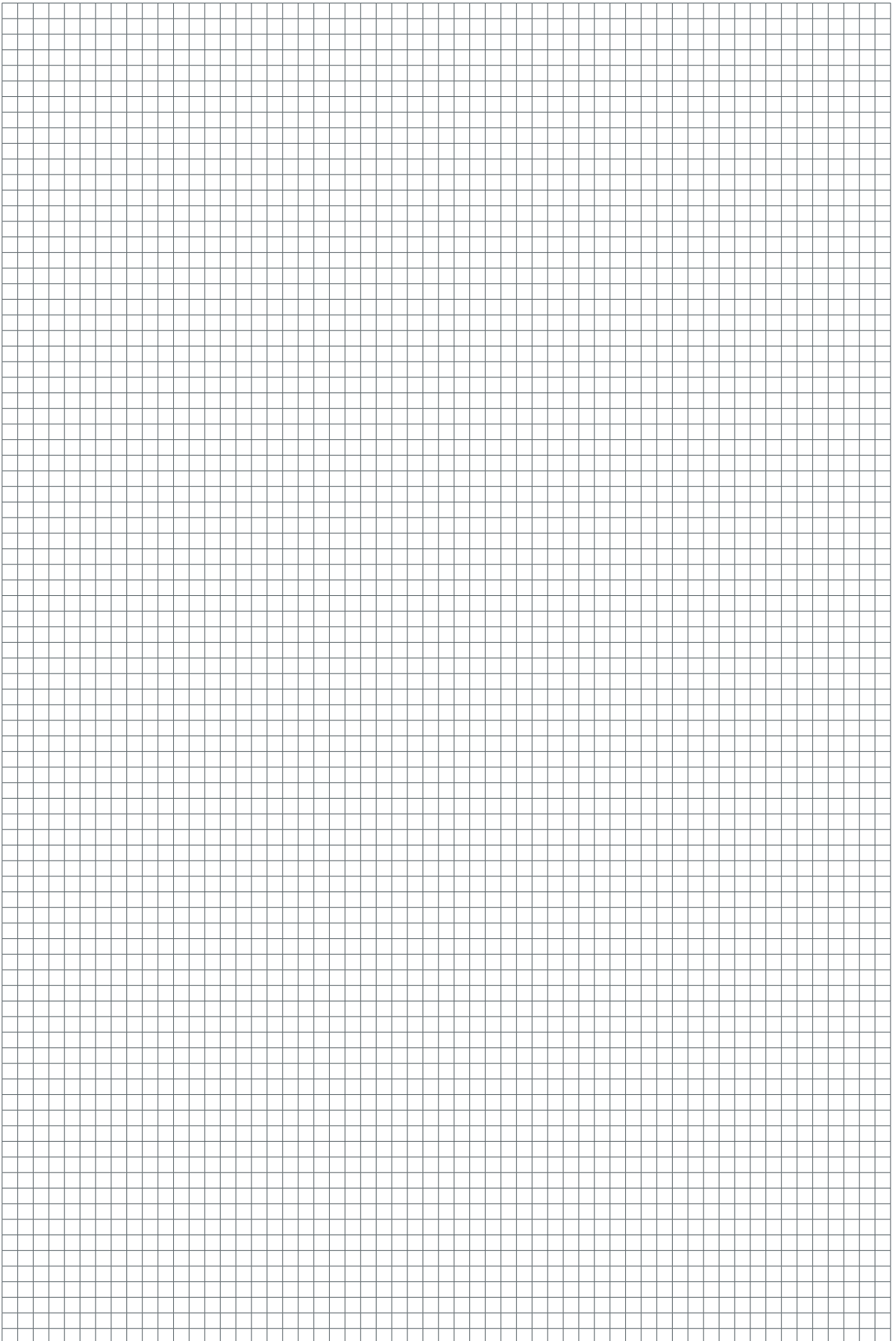

Dimensions and connections

The number and positions of the connections are optimized for the ETA hydraulics and control system.

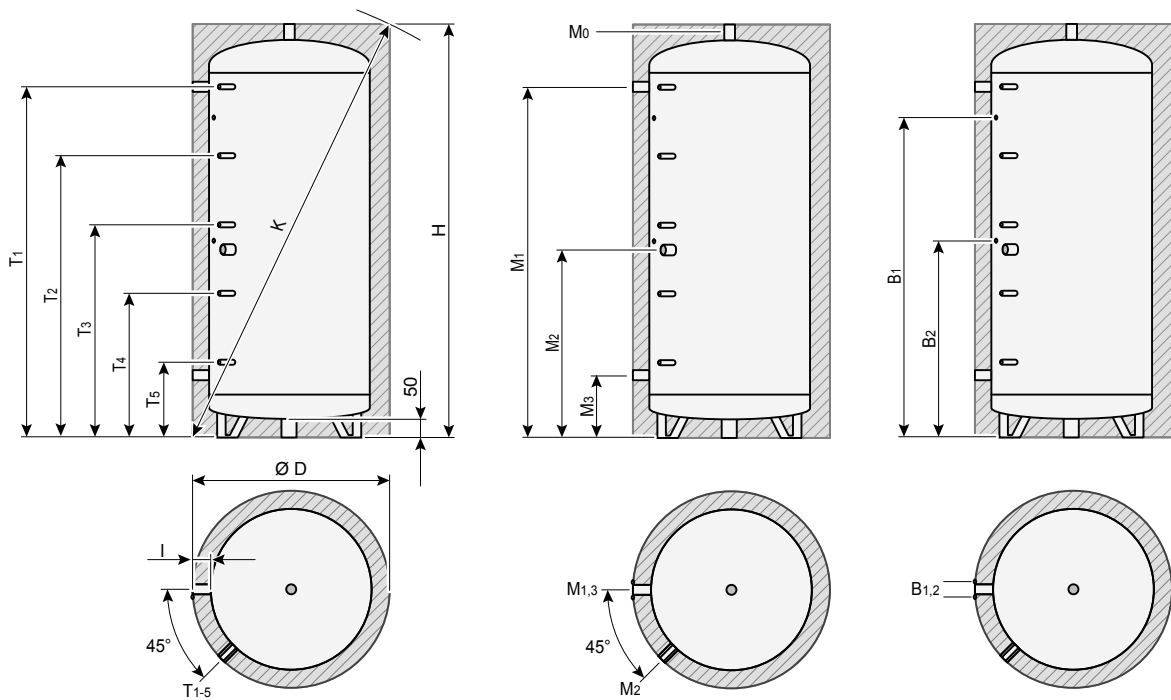

Technical data		Eco 500	
Volume		l	501
Heat retention loss S		W	73.7
Tank classification			B
Maximum permissible operating pressure		bar	3
Maximum permissible operating temperature		°C	95
Total weight		kg	62
Colour of the isolation			melon yellow
I	Insulation	mm	60
D	Diameter (with insulation)	mm	750
H	Height (with insulation)	mm	1,720
K	Tilted height (with insulation)	mm	1,880

Position height		Eco 500	
B ₁	Attachment (fresh water module)	mm	1,275
B ₂		mm	790
M ₀	1" coupling	top	
M ₁		mm	1,470
M ₂	1½" coupling	mm	750
M ₃	1" coupling	mm	250

Position height		Eco 500	
T ₁		mm	1,470
T ₂	Immersion sleeve 9 mm diameter	mm	1,125
T ₃		mm	850
T ₄	(for temperature sensor)	mm	575
T ₅		mm	300

TECHNICAL DATA
 SP STRATIFIED BUFFER 600 TO 2200 AND
 SPS 600 TO 1100

Dimensions and connections

The number and position of the connections is optimized for the ETA hydraulics and control system. The following figures show a Solar SPS stratified buffer with a supplemental solar exchanger (connections S_1 and S_2).

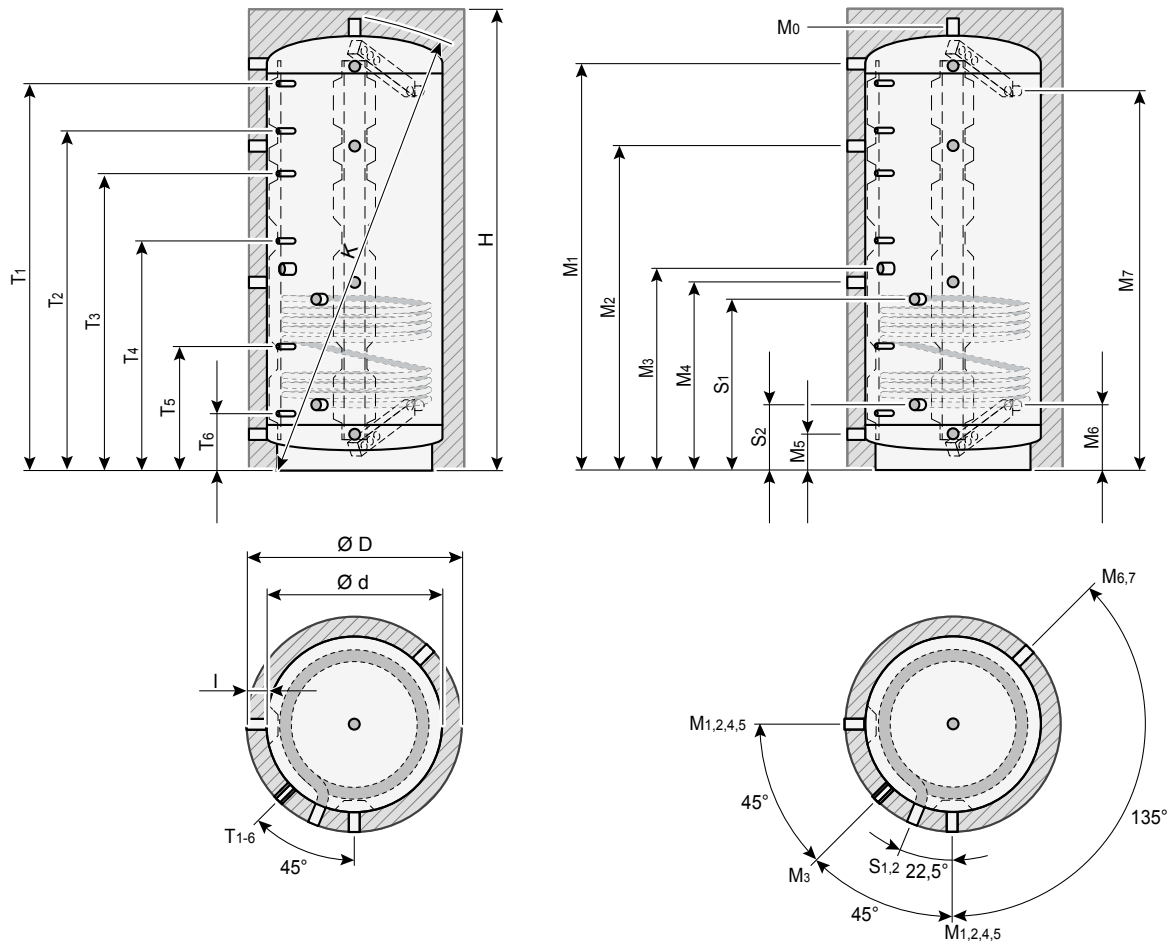

The M_3 connection without separator plate is intended for the return connection of boilers that are to heat only the upper half of the buffer, or for the attachment of an electric heating element with a 6/4" external thread.

The M_4 connection is designed specifically for the return from hot water tanks. By means of the separator plate a warm return flows to the middle of the buffer and a cold return to the lower third.

The M_6 and M_7 connections are only installed on stratified buffers SP 2200. These connections are equipped with an inflow lance for high outputs with a flow rate of up to 20 m³/h.

For the solar stratified buffer, a minimum collector size of 1 m² is required for each 100 litres. For smaller collector surfaces on larger buffers or very large solar heating systems, we recommend the ETA stratified charging module.

TECHNICAL DATA SP STRATIFIED
BUFFER 600 TO 2200 AND SPS 600 TO 1100

Technical data	Unit	SP 600 SPS 600	SP 825 SPS 825	SP 1000 SPS 1000	SP 1100 SPS 1100	SP 1650	SP 2200
Volume	l	600	825	1,000	1,100	1,650	2,200
Maximum permissible operating pressure	bar	3					
Maximum permissible operating temperature	°C	95					
Total weight (without solar heat exchanger)	kg	117	141	160	166	274	328
∅ D Diameter (without insulation)	mm	700	790	790	850	1,000	1,150
K Tilted height (without insulation)	mm	1,810	1,970	2,240	2,200	2,420	2,430
Insulation energy efficiency class "C"							
Tank classification*		C					
Heat retention losses S*	W	112.50	120.83	125.00	133.33	162.50	-
Colour of the insulation Melon yellow							
I Insulation	mm	100					
∅ D Diameter (with insulation)	mm	900	990	990	1,050	1,200	1,350
H Height (with insulation)	mm	1,800	1,939	2,219	2,150	2,370	2,380
Insulation energy efficiency class "B"							
Tank classification*		B					
Heat retention losses S*	W	85.4	96.7	104.6	108.3		
Colour of the insulation Silver							
I Insulation	mm	120					
∅ D Diameter (with insulation)	mm	940	1,030	1,030	1,090		
H Height (with insulation)	mm	1,830	1,970	2,250	2,180		

Position height	Unit	SP 600 SPS 600	SP 825 SPS 825	SP 1000 SPS 1000	SP 1100 SPS 1100	SP 1650	SP 2200	
M ₀		top						
M ₁	6/4" coupling	mm	1,595	1,718	1,998	1,910	2,095	2,080
M ₂		mm	1,240	1,393	1,513	1,535	1,710	1,735
M ₃	6/4" coupling (without separator plate)	mm	865	833	943	940	1,020	1,100
M ₄	6/4" coupling	mm	800	773	883	875	940	965
M ₅		mm	125	148	148	170	205	230
M ₆	2" coupling	mm	-	-	-	-	-	360
M ₇		mm	-	-	-	-	-	1,970
T ₁	Immersion sleeve 9 mm diameter (for temperature sensor)	mm	1,510	1,628	1,908	1,820	2,005	1,985
T ₂		mm	1,340	1,493	1,613	1,635	1,810	1,835
T ₃		mm	1,140	1,293	1,413	1,435	1,610	1,635
T ₄		mm	965	933	1,043	1,040	1,120	1,200
T ₅		mm	525	503	547	565	625	690
T ₆		mm	230	253	253	275	310	325

Additional technical data for Solar SPS stratified buffer		Unit	SPS 600	SPS 825	SPS 1000	SPS 1100
Optimum solar collector area (in terms of storage volume)		m ²	3-7	4-9	5-11	6-12
Maximum solar collector area (in terms of solar register)		m ²	15	15	18	20
Maximum permissible operating pressure (solar exchanger)		bar	16			
Maximum permissible operating temperature (solar exchanger)		°C	110			
Total weight (with solar heat exchanger)		kg	157	182	206	213
Solar exchanger surface		m ²	2.5	2.5	2.9	3.2
Volume of solar heat exchanger		l	15.5	15.5	18.0	20.0
Pressure loss at 1,000 l/h		mWs	0.31	0.31	0.36	0.39
S ₁	R1" coupling (solar heat exchanger connection)	mm	818	757	841	863
S ₂		mm	230	253	253	275

*The tank classification values specified by us for ETA SP/SPS and the heat retention losses apply only to the following combination: ETA SP/SPS stratified buffer storage and insulation for ETA SP/SPS NeodulPlus
Just for the calculation of the energy labelling of packages - NOT VALID AS ENERGY EFFICIENCY FOR HOT WATER STORAGE TANKS

Dimensions and connections

The number and position of the connections is optimized for the ETA hydraulics and control system.

The following figures show a Solar SPS stratified buffer.

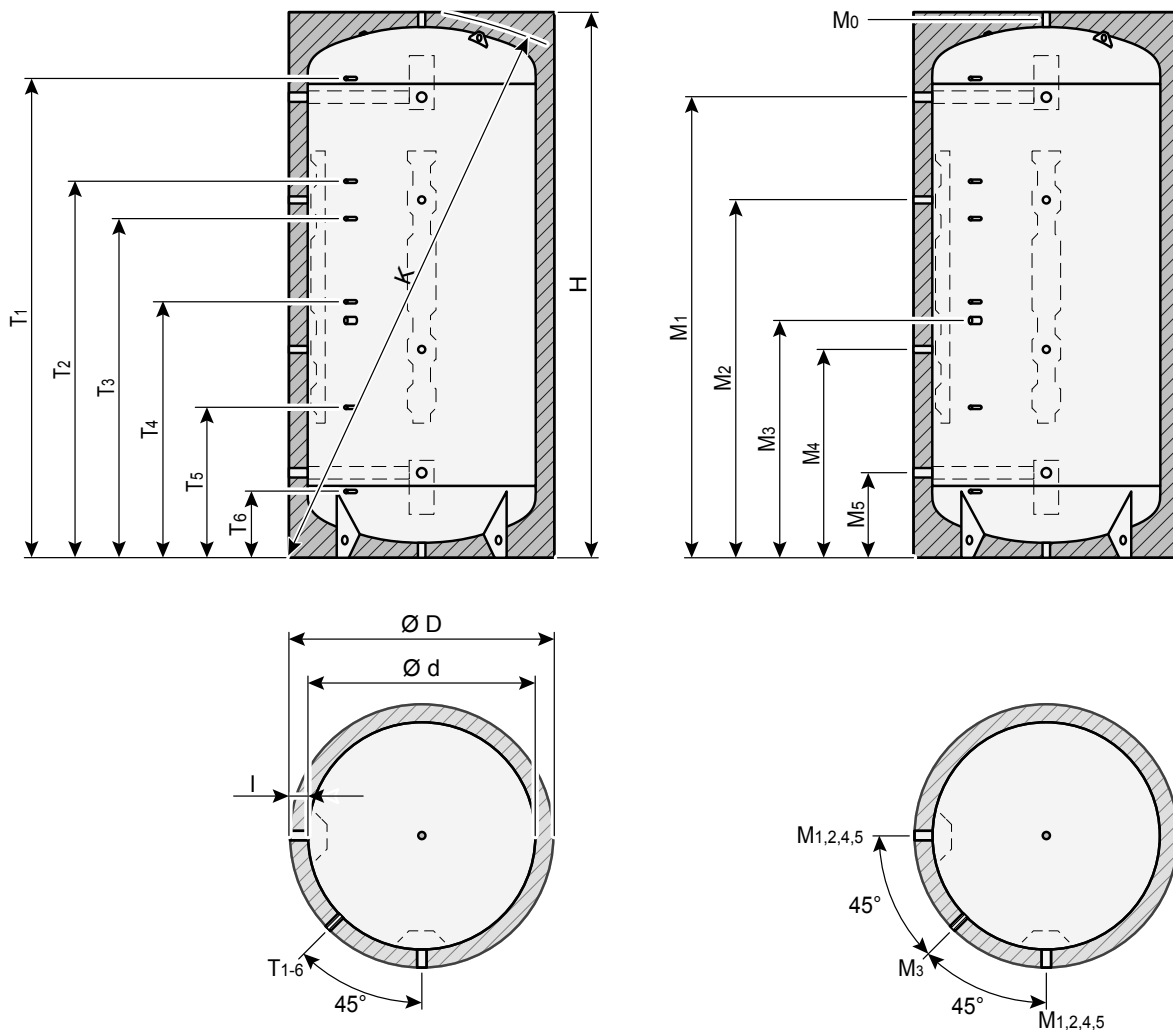

The M1 und M5 connections have a special inflow/outflow cylinder and are therefore designed for large boiler outputs up to 500 kW (25m³/h).

The M3 connection without separator plate is intended for the return connection of boilers that are to heat only the upper half of the buffer, or for the attachment of an electric heating element with a 6/4" external thread.

The M4 connection is designed specifically for the return from hot water tanks.

If more than two buffers are used, for hydraulic reasons they must be connected using external piping in a Tichelmann system.

The SP 3000–5000 tank range is only available without solar heat exchanger. For large volumes a solar heating system will be connected via external devices, such as the ETA solar stratification module, for example.

TECHNICAL DATA SP 3000 TO 5000 STRATIFIED BUFFER

Technical data		SP 3000	SP 4000	SP 5000	
Volume	l	3,000	4,000	5,000	
Maximum permissible operating pressure	bar	3			
Maximum permissible operating temperature	°C	95			
Total weight	kg	397	477	582	
Colour selection of the insulation		melon yellow			
I	Insulation	mm	100		
∅ d	Diameter (without insulation)	mm	1,250	1,400	1,600
∅ D	Diameter (with insulation)	mm	1,450	1,600	1,800
H	Height (with insulation)	mm	2,712	2,920	2,850
K	Tilted height (without insulation)	mm	2,740	2,950	2,890

Position height		SP 3000	SP 4000	SP 5000	
M ₀	6/4" coupling		top		
M ₁	2" coupling	mm	2,286	2,465	2,355
M ₂	6/4" coupling	mm	1,811	1,915	1,880
M ₃	6/4" coupling (without separator plate)	mm	1,176	1,300	1,245
M ₄	6/4" coupling	mm	1,041	1,145	1,110
M ₅	2" coupling	mm	426	455	495
T ₁		mm	2,386	2,565	2,455
T ₂		mm	1,911	2,015	1,980
T ₃	Immersion sleeve 9 mm diameter (for temperature sensor)	mm	1,711	1,815	1,780
T ₄		mm	1,276	1,400	1,345
T ₅		mm	766	835	835
T ₆		mm	326	355	395



Simple and can be controlled from anywhere

Good technology is characterized by being user-friendly. You don't have to be a technician to use ETAtouch's many functions.

ETAtouch: the touchscreen as heating control

The days of confusingly arranged buttons and controls are over, because with the touchscreen of the ETA control system you can make all settings conveniently and easily. The icons are self-explanatory. Whether you generally have warmer or cooler temperatures, want to change the time for night setback or want to switch to setback mode during your vacation - you will intuitively tap on the right illustration without any operating instructions!

You can control your heating system via touchscreen and also have an overview of all integrated components such as buffer tanks, solar systems or hot water tanks.



Heating, night setback, Holiday setting: the operation is immediately clear



the free of charge internet platform

If your ETA control is connected to the internet, you can view and change all heating settings on your smart phone, tablet or PC. So you have your heating under control, no matter where you are!

When you log in at www.meinETA.at, you will see the touchscreen exactly as if you were standing directly in front of the boiler. If necessary, mein-ETA will also inform you free of charge by email about your heating system.

Within your own house network, direct access to the ETAtouch control of your heating system can also be achieved via VNC.

Quick help

Give your installer temporary access rights to your meinETA account. This way he can prepare for his visit to you. And maybe the technician doesn't even have to come because, thanks to myETA, he can tell you over the phone what you need to do to ensure that your heating system is optimally adjusted. You can see who can access your control via the status display. You always decide who belongs to your partner network!



For tablets, smartphones and PCs

meinETA runs on all common operating systems such as iOS or Android. meinETA can be loaded via PC using any modern internet browser.



Everything is very simple



Perfect for your smart home

The ETAtouch control can be easily integrated into common smart home systems as well as into a building management system (BMS). The mini server of the Loxone system exchanges data directly with the boiler via a ModbusTCP interface. And all you need to connect to a KNX bus system is the optionally available ETA KNX interface and a few simple clicks.

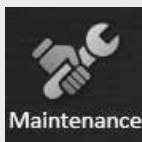

Maintenance assistant

Simply maintain your boiler yourself: the instructions on the boiler's touch display guide you step by step through the annual cleaning.

ETA individual room control interface example:

Whether Loxone, KNX or ETA individual room sensor with or without display: everything can be controlled via ETAtouch. It always passes on the correct signals to the valve controllers, which control how much hot water should come through to the respective room or heating section.

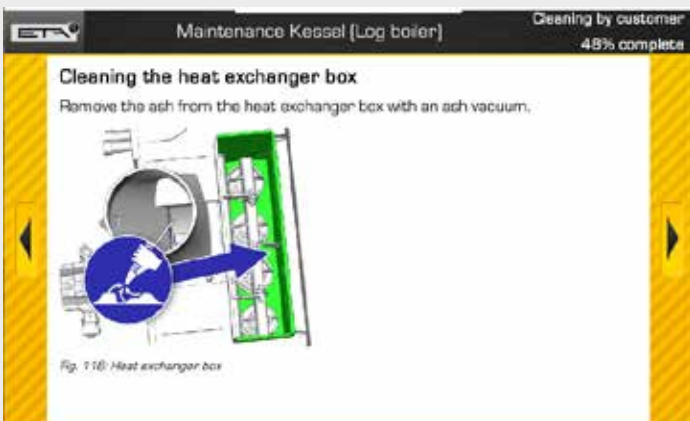
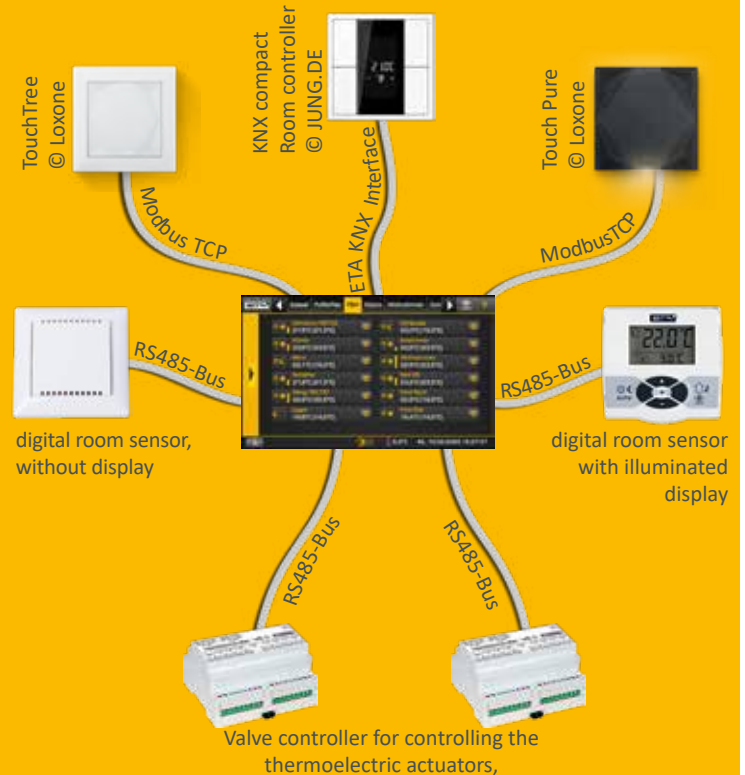

Everything on one display: the ETA Standard

A modern heating system is only effective if it is well-controlled. ETAtouch takes care of that.

At no added cost, the ETAtouch control system already includes all functions for two heating circuits, hot water supply via tank or instantaneous hot water module, as well as for the integration of a solar heating system. All ETA heating boilers also come with a LAN connection as standard. If you connect the boiler to the internet, you can easily control all components from a PC, tablet or smartphone.

Boiler and combustion regulation*

Speed-controlling the several components save power. The lambda and ignition time regulation increases efficiency. All components relevant to operation are monitored.

Buffer storage tank management**

Three to nine sensors in the tank control the heat generator in the system and distribute the energy to the different consumers. From using five sensors, cascading regulation, QM-Holz and peak load management are part of the ETA Standard.

Domestic hot water preparation*

Is made possible both via the ETA instantaneous hot water module but also via the hot water tank or combination tank. For all variants, circulation pumps can be controlled with time and/or requirement programs.

Solar heating systems**

Single or double circuit solar heating systems with one or two tanks, zone loading via the ETA stratified charging module and also two collector fields as well as three consumers are controlled.

Two weather-controlled mixing heating circuits**

They run with a weekly program which allows many time windows and automatic and/or manual additional functions. The system can optionally be expanded with room sensors and remote control.



Comprehensible also without the need for an operating manual: The symbols on the touchscreen are self-explanatory. So controlling the heating system becomes child's play.

Additional system functions

Detection of third-party heating devices, such as oil boilers, gas boilers, heat pumps and wood burning stoves, thermostat or differential temperature thermostat, external demand from external devices such as heating fans, control of transmission lines, with or without mixers, and also of heat transfer stations, single room control systems, for example.

Wall-mounted control box for more complex systems

All control systems can be extended with wall-mounted control boxes, with or without touchscreen.

* Control system and sensor included in standard delivery scope

** Control system depends on configuration, sensors are available as accessory

From Hausruckviertel to the world

ETA specialises in the manufacture of biomass heating, i.e. log, pellet and wood chip boilers. The most modern technologies combined with naturally growing resources.

ETA is efficient

Technicians designate the efficiency of a heating system with the Greek letter η , pronounced „eta“. ETA boilers stand for more heat with less fuel consumption, environmental soundness and sustainability.

Wood: old but excellent

Wood is our oldest fuel - and our most modern: There is a lot of history - from open fires in front of caves to modern biomass boilers. In the middle of the 20th century, the number of wood heating systems briefly fell. Oil heating became the new, hyped option. A brief interlude in comparison to the consistency of wood. Today, we know that heating with fossil fuel has no future. It contributes to global warming and harms the environment. Supply security is also not guaranteed in the long term, as fossil fuels are being depleted, aren't renewable and often come from unstable regions. While wood by contrast is a cheaper, locally grown, renewable raw material that does not pollute the climate when burnt. No wonder wood heating is booming!

Comfort with many components

Since December 1998, the Upper Austrian company ETA has been designing and building a new generation of wood-fired boilers. They are full of patented technologies and the most modern control technology – making them easy to use. Convenience and efficiency make ETA products so popular around the world. With a production capacity of up to 35,000 boilers per year and a global export proportion of around 80%, ETA is one of the leading biomass boiler producers.

You get more than just a boiler

Anyone who decides on a wood or pellet boiler from ETA is choosing sustainability. This is not just in terms of fuel, but encompasses responsibility across the board, with sustainable workplaces in the region. More than 400 employees in Hofkirchen an der Trattnach have the best working conditions – including an in-house restaurant, bright assembly and storage halls, a fitness room and a sauna. There is even a free electric charging station for electric cars, which is supplied by the in-house photovoltaic system. This also covers all the power needed of a production hall and thus saves around 230 tonnes of CO₂ per year.





ETA Pelletboiler

ETA PU PelletsUnit	7 - 15 kW
ETA ePE pellet boiler	7 - 56 kW
ETA PC PelletsCompact	20 - 105 kW
ETA ePE-K pellet boiler	100 - 240 kW



ETA condensing heat technology

ETA ePE BW pellet boiler	8 - 62 kW
ETA BW condensing heat exchanger PU	7 - 15 kW
ETA BW condensing heat exchanger PC	20 - 105 kW



ETA SH log wood boiler and TWIN pellet boiler

ETA eSH log wood boiler	16 - 20 kW
ETA eSH-TWIN combination boiler with ETA eTWIN pellet boiler	16 - 20 kW 16 kW
ETA SH log wood boiler	20 - 60 kW
ETA SH-P log wood boiler with ETA TWIN pellet boiler	20 - 60 kW 20 - 50 kW



ETA wood chip boiler

ETA eHACK wood chip boiler	20 - 240 kW
ETA HACK VR wood chip boiler	250 - 500 kW

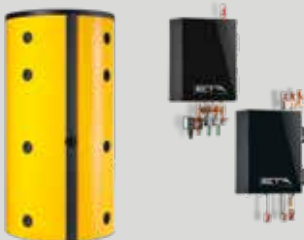

ETA buffer tank

ETA buffer	500 l
ETA buffer tank SP	600 - 5.000 l
ETA buffer tank SPS	600 - 1.100 l

ETA hydraulic modules

- ETA fresh water module
- ETA stratified charging module
- ETA system separation module
- ETA mixing circuit module
- ETA heat transfer module and station

Your heating specialist will be happy to advise you:



ETA Heiztechnik GmbH
 Gewerbepark 1
 A-4716 Hofkirchen an der Trattnach
 Tel.: +43 7734 2288
 Fax: +43 7734 2288-22
 info@eta.co.at
 www.eta.co.at

Technical changes and mistakes reserved

In order to provide you the benefits of our continuous development, we reserve the right to change specifications without prior notice. Printing and typesetting errors or changes of any kind made in the interim are not cause for claims. Individual configurations depicted or described here are only available as options. In the event of discrepancies between individual documents regarding the scope of delivery, the information provided in our current price list shall prevail. Images and symbols may contain options that are available for an additional cost.

Photo source: ETA Heiztechnik GmbH, Lothar Prokop Photographie, istockphoto, Thinkstockphotos, Photocase, Shutterstock.
 94710-EN, Prospekt Schichtpuffer ETA EN, 2024-06

